

prosmt

AFM-11U / AFM-11F

Manuel Komponent Bacak Kesme Bükme Makinesi

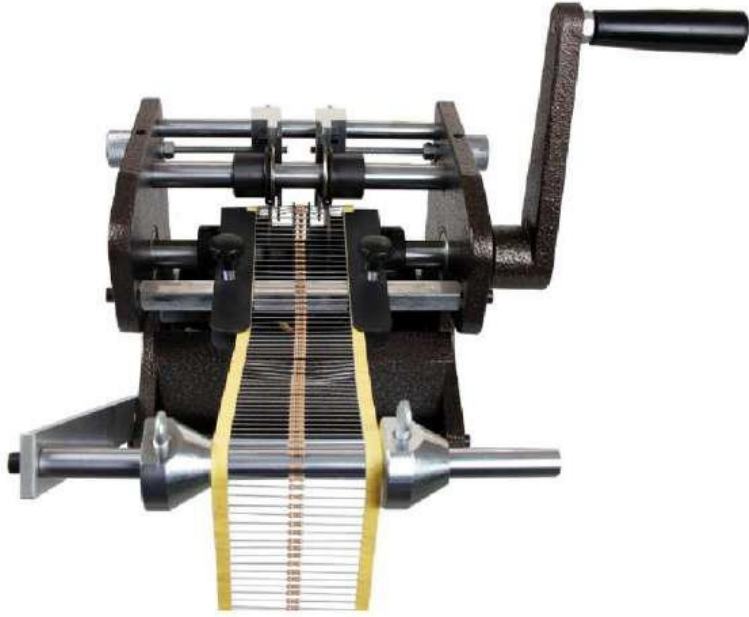

AFM-11U / AFM-11F

Manuel Komponent Bacak Kesme Bükme Makinesi

I. Product Structure

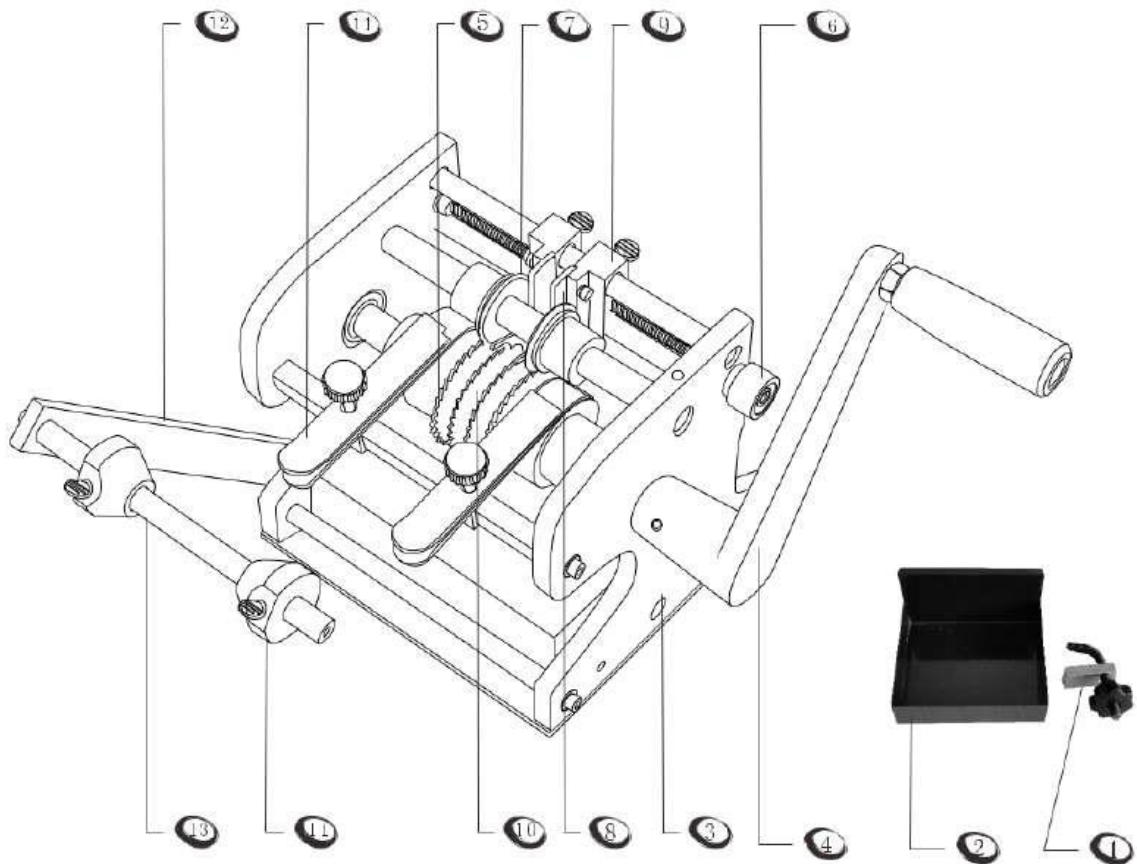

Instruction

- | | | |
|-------------------|-----------------------------------|-----------------------------------|
| 1. Bench Holdfast | 6. Adjusting Handle | 11. Incoming Charge Locating Rack |
| 2. Take-up box | 7. Cut-Off Tool | 12. Material Belt Support Rod |
| 3. Host Machine | 8. Shaping Piece | 13. Material Belt Support Shaft |
| 4. Jiggle Bar | 9. Shaping Piece Positioning Seat | 14. Material Belt Located Block |
| 5. Cut-Off Gear | 10. Shaped Gear | |

AFM-11U / AFM-11F

Manuel Komponent Bacak Kesme Bükme Makinesi

II. Product introduction

AFM-11U/AFM-11F Hand band-type resistance forming machine is mainly used for bend-forming axial type braided resistance, capacitance, inductance, diode and other electronic components into horizontal type (U shape)/ vertical type (F shape) special machine. This machine uses high precision part and quality material. Its action principle is to complete cutting off component feet by interaction of a pair of cut-off gear and cut-off tool and then complete processing for a pair of shaped gear and shaped blade.

The machine structure is light and handy with easy operation. It has great production efficiency. Each round of band-type can shape 36 components. The machine is hand-operated and does not need any power supply.

Our quality policy: "continuous improvement, Persistent effectiveness, customer utmost". Zhengbang Electronic will serve you sincerely.

III. Technical Parameters

Model	AFM-11U	AFM-11F
A	6-40	1-18
B	3.0-15	2.5-20
C	1.2mm	2-3mm
D	1.5-8	
E	0.35-1	
H	Null	25(N/a)
P	Null	2.5-13.5

Note: U-shaped machine and F-shaped machine are different machines.

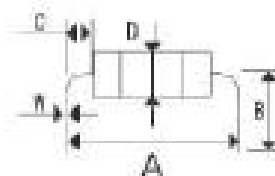

U Type

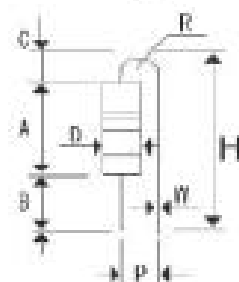

F Type

AFM-11U / AFM-11F

Manuel Komponent Bacak Kesme Bükme Makinesi

IV. Installation and Debugging

1. Remove the package and read this manual carefully.
2. Take out and place the machine in good position, and then secure the machine on the table.
3. Take out the machine, install and rotate the hand shank that each rotary gear can run normally.
4. Loosen the set screws on the incoming guide rail and move the incoming guide rail to both sides of the machine.
5. Use 4# socket head wrench to unscrew the set screws on the cut-off gear, the shaped gear and shaped base. According to the component requirement, adjust the shaped gear (middle ones) and the cut-off gear (side ones) to the needed position (Note: to be symmetric to the stripping piece position). Rotate the adjusting knob of shaped base to move around the Shaping Piece, making the spacing between the Shaping Piece and the shaped gear conform to the diameter of component pin. Finally, fix the screw of aforementioned parts tightly. The width of the inside diameter between two pins of the shaped component is the distance between the outside diameters of two shaped gears. The length of component cut foot is the distance between the diameters of two cut-off gears.

V. Operational Approach

1. Place the braid component on the rack feeder; adjust the width of the incoming guide rail on both sides to be the same with the width of braid component and let the braid component go through the rail groove. U-shaped: place the main body of component at two shaped gears (Picture 1). F shaped: place the main body of at one side of small mouth gear and between the cut-off gears (Picture 2). Screw up the set screws on the incoming rail, and lay the main body of on the shaped gear and the cut-off gear.



Fig. (1) U Type



Fig. (2) F Type

AFM-11U / AFM-11F

Manuel Komponent Bacak Kesme Bükme Makinesi

2. Rotate the hand shank at a uniform speed; perform the cut-off process by sending the components into the cut-off gear and the cut-off tool; finish the shaping by the shaped gear and the Shaping Piece. The completed component after going through the stripping device will fall into the component collection groove until all components are processed.

Note: (1) The spacing between the shaping piece and the shaped gear is the pin diameter of component.

(2) F-shaped component shaping angle can be regulated by the adjustable screw on the shaping piece base.

(3) Do not rotate the hand shank too fast.

(4) Clear the waste material timely during the operation.

VI. Notice

1. The shaping axle and the blade axle shall be lubricated frequently.
2. The cut-off gear, the cut-off blade, the shaped gear and the shaping piece are processing and heat treatment pieces, which shall avoid collision to prevent rupture.
3. The blending gap shall be regulated by the pin diameter of component. Slightly fat at the turn of component pin is normal, but the copper of component pin shall not be exposed.
4. Gear biting of the component shall be strictly prohibited so as to avoid the rapture of gear shape.

VII. Accessory

1. Jiggle Bar	1 piece
2. Rack Feeder	1 set
3. Component Collection Groove	1 piece
4. Socket Head Wrench	1 set
5. Manual	1 piece
6. Certificate of Quality	1 piece

The warranty period of this machine is 12 months since the purchase date. We will offer free maintenance during warranty period if it does not belong to man-made fault. If it is man-made fault or beyond the warranty period, we will charge the maintenance cost according to the situation. We provide lifelong maintenance to our machines.

