



UM08-CSZ1236

User's Guide



Version 1.0A

Contents

1.	Product Introduction	2
1.1	Packing Contents	2
1.2	CSZ1236 Lens Assembling	2
1.3	IR Remote controller.....	5
1.4	Microscope menu functions.....	8
1.5	Microscope introduction:	21
1.6	Microscope Focus	25
1.7	Microscope accessory.....	28
2.	Printed Notice.....	29
2.1	Maintenance.....	29
2.2	Product Specification.....	30

1. Product Introduction

1.1 Packing Contents

The box contains 1 camera and 9 accessories.

Item	Q'ty	Item	Q'ty
UM08 Camera	1	White Balance Card	1
HDMI Cable	1	IR Remote Control	1
Power adaptor	1	User's Guide	1
S107 Stand	1	CSZ1236 Lens	1
Stand assemble guide	1	Gooseneck Light	1

1.2 CSZ1236 Lens Assembling

1.2.1 Fix microscope

Screw CSZ1236 Lens with UM08 Camera, the adjustment screws will face front or side. The adjustment screws is for adjust Aperture, Focal Length and Focus. Firstly, assemble the stand S107 then tighten ① Camera with S107 ②.

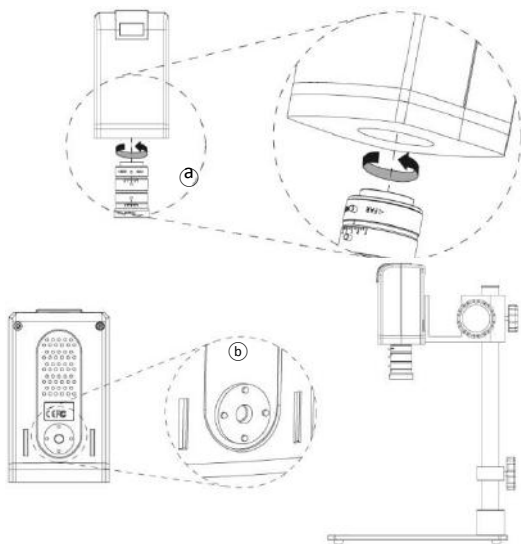

1.2.2 Start to use microscope

Connect the HDMI cable (c) and adaptor (d) within the box to HDMI monitor and power. See below:

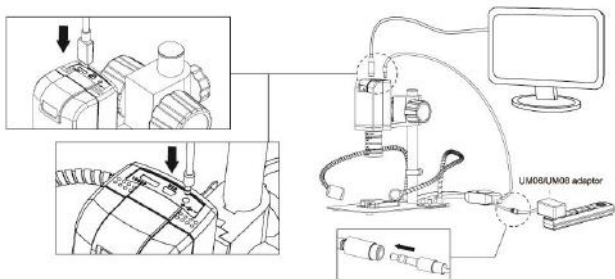



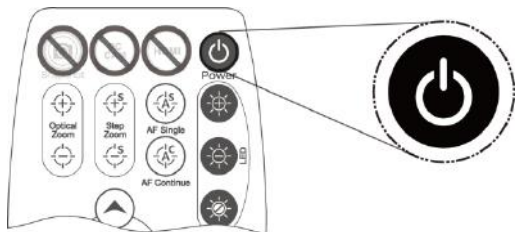

1.2.3 Power On/Off

Press Power  to turn on microscope.







1.3 IR Remote controller

The microscope operation and functions is controlled by the IR remote controller.

- (1) Power  : Turn on/off.
- (2) HDMI  : No Function.
- (3) PC CAM  : No Function.
- (4) Snapshot  : No Function.
(only with IMB05)

- (5) LED Adjustment: No Function
- (6) Motor Reset  (Recalibrates entire operation) : Returns to the lens position. If a loss of electricity occurred during operation, please reset the operation.

- (7) Manual focus: Press Zoom out  or zoom in  to find clear focus.
 - (7-1) Zoom in  : Zooms in; speed increases when held.
 - (7-2) Zoom out  : Zooms out; speed increases when held.

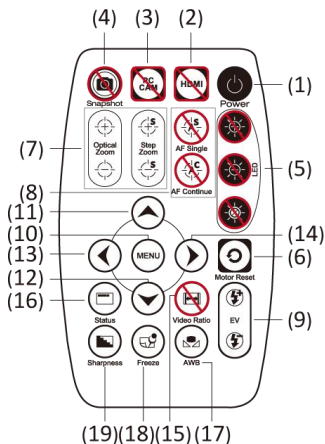

- (8) Autofocus: Does not suggest to use this function in CSZ1236 model.

Press one time to search focus in current area, press and hold for 2 seconds to search focus in whole area.

Single Autofocus : Focus one time.

Continuous autofocus : Re-focus whenever image blurred.

- (9) Exposure Value: 18 levels of exposure value are selectable, from -9~Auto~+9.

(9-1) Increase  : Use to increase exposure when the image is too dark.

(9-2) Decrease : Use to decrease exposure when the image is too bright.

- (10) Menu on Screen  : Open/close menu for setting. Refer to Section 1.4.

(11) Up  : Choose the previous item

(12) Down  : Choose the next item

(13) Left  : Choose the next value

(14) Right  : Choose the last value

(15) Video Ratio  : No Function

(16) Status Bar  : Suggest to OFF the Status Bar in CSZ1236 model.



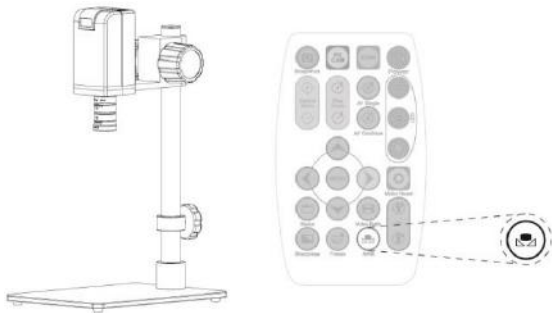





(17) Auto White Balance Calibration  : To calibrate the white balance, place the white balance card (included in box) under the lens, focus until clear, and choose On. Because the white balance is sometimes influenced by external light sources, it is recommended to calibrate the white balance if the color seems off or incorrect.









(18) Image Freeze  : ON/Off to freeze or unfreeze the image.

(19) Sharpness : On/Off to set sharpness at Minimum and Maximum level.

1.4 Microscope menu functions

There are 8 functions in menu, press Up  and Down  to choose item, Left  and Right  to turn on/off or adjust parameter. Enter  means more functions, press Menu  to enter next function or confirm.  means no more settings. Return to return last page, or press Left  or Right  to choose “End” to return preview window.

MAIN MENU	
1.EXPOSURE	
2.BACKLIGHT	OFF
3.WHITE BAL	ATW
4.NR	
5.SPECIAL	
6.ADJUST	
7.RESET	
8.EXIT	

1.4.1 EXPOSURE

To set exposure time, see below:

EXPOSURE	
1.SHUTTER	AUTO
2.AGC	■■■■■■■■■■■■■■■■■■■■ 0
3.SENS-UP	———
4.BRIGHTNESS	■■■■■■■■■■■■■■■■■■■■ 40
5.D-WDR	OFF
6.DEFOG	OFF
7.RETURN	RET

- (1) Shutter: Digitally control amount of light, the amount is smaller the image is darker and the frame rate is also slower.
- (2) AGC (Auto Gain Control): auto control the brightness based on setting when light is not enough.
- (3) SENS-UP : Only available when item (2) AGC value is larger than 0, use to increase Sensor to light's sensibility.
- (4) Brightness Adjust image brightness.

- (5) D-WDR: Digital-wide dynamic range. Digitally adjusting exposure in areas of the frame to maintain optimum detail in both the shadows and highlights of the image.
- (6) DEFOG : De-Fog. When observing under strong light or special environment, use Defog function to see clear image. Below fig for De-Fog setting.

DEFOG	
1.POS/SIZE	↕
2.GRADATION	LOW
3.DEFAULT	↕
4.RETURN	RET

(6-1) POS/SIZE : Adjust de-fog position and area.

(6-2) GRADATION : To set gradation levels near the edge of defog area.

(6-3) DEFAULT : Return to default setting.

(6-4) RETURN: Return to last page.

1.4.2 BACKLIGHT

Press left/right button to choose turn on/off Backlight mode.

(1) OFF : Disable backlight function.

(2) WDR: Wide Dynamic Range. WDR allows an imaging system to correct for the intense back light surrounding a subject

and thus enhances the ability to distinguish features and shapes on the subject. See below for setting WDR.

WDR	
1.GAIN	LOW
2.WDR OFFSET	0
3.RETURN	RET

(2-1) GAIN: Set WDR gain level to raise up brightness of darker image.

(2-2) WDR OFFSET : Wide Dynamic Range OFFSET.

(2-3) RETURN: Return to last page.

(3) BLC (Back Light Compensation)

To adjust brightness for darker image in back light environment.

(3-1) GAIN: To adjust brightness level.

(3-2) AREA: Choose the back light compensation area and size.

(3-3) DEFAULT: Return to default setting.

(3-4) Return: Return to last page, or press left or right to choose “End” to return preview window.

BLC	
1.GAIN	MIDDLE
2.AREA	↓
3.DEFAULT	↓
4.RETURN	RET

(4) HSBLC (High Suppress Back Light Compensation)

To identify the over luminance area by backlight, and proceed masking the area.

HSBLC	
1.SELECT	AREA1
2.DISPLAY	ON
3.LEVEL	20
4.MODE	ALL DAY
5.BLACK MASK	ON
6.DEFAULT	↓
7.RETURN	RET

(4-1) SELECT: Select the areas which needs to be adjusted.
4 areas are selectable.

(4-2) DISPLAY: Display the selected area.

(4-3) LEVEL: Set value to judge if the image is too bright.

(4-4) MODE: Super back light compensation mode.

(4-5) ALL DAY: Day mode.

(4-6) NIGHT: Night mode.

(4-7) BLACK MASK: Reverse the over exposed area

(4-8) DEFAULT: Return to factory default setting.

(4-9) RETURN: Return to last page.

1.4.3 MANUAL WB

Calibrate the white balance.

- (1) AWB: Auto white balance.
- (2) ATW: Auto tracing white area and calibration.
- (3) AWC->SET: Semi-auto white balance. Use to track the white color from current image.
- (4) MANUAL: Manually adjust blue and red values to find correct white color. Refer to below fig.

MANUAL WB	
1.BLUE	50
2.RED	50
3.RETURN	RET

1.4.4 NR

Noise Reduction : (NR) To obtain high quality output image and increase file compression. See below:

2D&3D NR	
1.2DNR	ON
2.3DNR	ON 
3.RETURN	RET

- (1) 2D NR : ON/OFF, Edge Preserving 2D NR.
 (2) 3D NR : ON/OFF, Motion Adaptive 3D NR. See below:

3D NR	
1.SMART NR	OFF
2.LEVEL	85
3.START .AGC	0
4.END .AGC	0
5.RETURN	RET

- (3-1) SMART NR: Distinguish the moving object not moving noise, and auto close the "3D NR".

3D SMART NR	
1.SENSITIVITY	50
2.RETURN	RET

- (3-1-1) SMART NR : The sensitivity to detect the moving object. The lower value gets higher sensitivity.
 (3-1-2) RETURN: Return to last page.
 (3-2) LEVEL : The threshold to judge noise.
 (3-3) START AGC : Start auto gain control. When AGC value is higher than setting, will start auto gain.
 (3-4) END AGC : End auto gain control. When AGC value is higher than setting, will end up auto gain.

(3-5) Return: Return to last page.

(3) Return: Return to last page.

1.4.5 SPECIAL

Set special functions:

SPECIAL	
1.D-EFFECT	↕
2.MOTION	OFF
3.LANGUAGE	ENG ↕
4.DEFECT	↕
5.VERSION	010000
6.RETURN	RET

(1) D-EFFECT: There are few more functions in D-EFFECT, but (1-3), (1-4) and (1-6) function can only turn on one item at one time. Press Left ◀ or right ▶ to turn on or off.

See below functions:

D-EFFECT	
1.FREEZE	OFF
2.MIRROR	OFF
3.D-ZOOM	OFF
4.SMART D-ZOOM	OFF
5.NEG . IMAGE	OFF
6.DIS	OFF
7.RETURN	RET

- (1-1) FREEZE: Turn ON/OFF to freeze image. If Freeze function is turn on, the (1-2) Mirror function can not be used at the same time
- (1-2) MIRROR: Image rotatory. (Horizontal or Vertical)
- (1-3) D-ZOOM: Digitally enlarge the chose area. Digital zoom selection can from 1-62 times. See below setting for D-Zoom.

D-ZOOM	
1.PIP	-----
2.D-ZOOM	X 2.0
3.PAN&TILT	↕
4.DEFAULT	↕
5.RETURN	RET



- (1-3-1) PIP: No function.
- (1-3-2) D-Zoom: Set digital zoom times.
- (1-3-3) PAN&TILT: To set the enlarge position.
- (1-3-4) DEFAULT: Return to default setting.
- (1-3-5) RETURN: Return to last page.
- (1-4) SMART D-ZOOM: Assign 1 or 2 areas to enlarge the image from 1-62 times whenever detected the object moves. The Smart D-zoom will automatically enlarge

the assigned area for few seconds and then return to original image.

SMART D-ZOOM	
1.SELECT	AREA1
2.DISPLAY	ON↵
3.SENSITIVITY	3.0
4.PIP	———
5.D-ZOOM	X 4.0
6.TIME	3
7.DEFAULT	↵
8.RETURN	RET

- (1-4-1) SELECT: Choose the enlarge area, totally 2 areas.
- (1-4-2) DISPLAY: Display enlargement frame. Position and area can be set in (1-4-1)
- (1-4-3) SENSITIVITY: The sensitivity to detect whenever object moves. The lower value gets the higher sensitivity.
- (1-4-4) PIP: No Function.
- (1-4-5) D-Zoom: Set magnification times.
- (1-4-6) TIME: Set the enlargement waiting time.
- (1-4-7) DEFAULT: Return to default setting.
- (1-4-8) Return: Return to last page.

- (1-5) NEG. IMAGE: Turn On/Off Negative image.
- (1-6) DIS: Digital Image Stabilization function.
- (1-7) RETURN: Return to last page.
- (2) MOTION: Detect the moving object, see below setting.

MOTION	
1.SELECT	AREA1
2.DISPLAY	ON 
3.SENSITIVITY	 30
4.MOTION VIEW	ON
5.DEFAULT	
6.RETURN	RET

- (2-1) SELECT: Select the areas which needs to be detected. 4 areas are selectable.
- (2-2) DISPLAY: Display the selected area. Position and area can be set in (2-1).
- (2-3) SENSITIVITY: The sensitivity to detect whenever object moves. The lower value gets the higher sensitivity.
- (2-4) MOTION VIEW : Mark specific area to identify the moving object.
- (2-5) DEFAULT: Return to default setting.
- (2-6) RETURN: Return to last page.

- (3) LANGUAGES: 16 languages are selectable.
- (4) DEFFECT: Dead Pixel compensation.



DEFFECT	
1.LIVE DPC	AUTO
2.STATIC DPC	ON 
3.RETURN	RET

- (4-1) LIVE DPC: Dead Pixel Correction. Correct the live dead pixel during preview.

LIVE DPC	
1.LEVEL	 80
2.RETURN	RET

- (4-2-1) LEVEL: Set the threshold value to judge if it needs RETURN: Return to last page.

- (4-2) STATIC DPC: Static Dead Pixel Correction, scan and find the dead pixel then save the position for correction.
Note: Please do not change this setting.

STATIC DPC	
1.START	
2.LEVEL	 5
3.SENS-UP	x 8
4.AGC	 8
5.RETURN	RET

- (4-2-1) START: Start to do Static Dead Pixel correction.
- (4-2-2) LEVEL: Set the threshold value to judge if it needs to be corrected.
- (4-2-3) SENS-UP: Raise up the sensor's sensitivity to compensate the dead pixel.
- (4-2-4) AGC: Auto Gain Control. When light is not enough, AGC will follow the threshold setting to compensate the dead pixel.
- (4-2-5) RETURN: Return to last page.
- (4-2-2) to be corrected.

(5) VERSION: Firmware version.

(6) RETURN: Return to last page.

1.4.6 ADJUST

See image adjust as below fig.



- (1) SHARPNESS: Adjust Sharpness, higher value increases the higher contrast along/near edges of the image.

(2) LSC : Lens Shading Correction. Use Lens shading correction to average the luminance of image.

1.4.7 RESET

Return to factory default setting. Press Left/right button to choose “CHANGE” to return default.



1.4.8 RETURN

Exit from menu.

1.5 Microscope introduction:

1.5.1 IR Remote Area/Indicator

When both (f) and (g) LED indicator blinks, the microscope is in standby mode.

Caution: Please remove the transparent protection sheet on the IR receiver area.

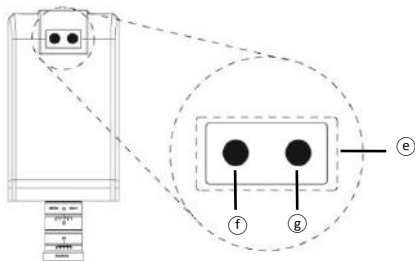

- (1) IR remote control aiming area (e): The indicator will blink whenever buttons are pressed. If the indicator did not blink means the signal was not delivered and please repress again.
- (2) HDMI indicator (f) : When lit up, the microscope is in HDMI mode. If light blinks, means microscope does not connect with monitor.

1.5.2 Power/USB/HDMI port

Caution: Please hold the cable when remove from microscope and do not disassemble cables forcefully.

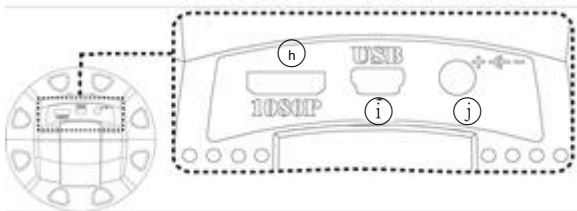

- (1) HDMI (h): The HDMI port is used to connect the microscope to a screen. Connect the microscope to the screen using the HDMI cable from the box. * For TV screen connections, make sure to choose the homologous image ratio and format.
 - (2) USB (i) : To use with accessory IMB04 for focus control.
 - (3) Power (j) : Power adaptor is only compatible with the cord in the box.
- ### 1.5.3 Stand gear box

Assemble the stand and then screw the microscope onto the universal joint (k) on the gear box.

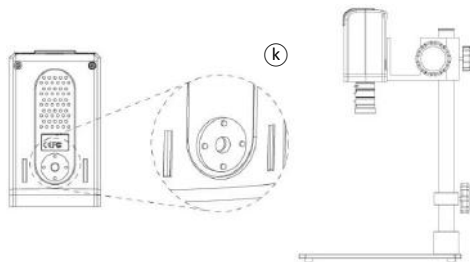

1.5.4 Illuminance

Gooseneck Light ①: Insert the Gooseneck light clip into base near the pole, tighten the screws. Connect power with UM08's power adaptor.

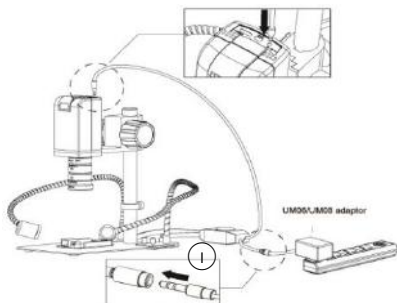

1.6 Microscope Focus

The working distance for CSZ1236 lens is 300mm~20mm. The higher magnification, the smaller FOV and the shorter working distance. On the contrary, the smaller magnification, the wider FOV and longer working distance. There are 3 adjustment screws on CSZ1236 Lens. The function as following:

- (A) Focus Adjustment: Loose the screws and rotate left/right toward FAR/NEAR to find clear image.
- (B) Aperture Adjustment: Recommend to set Aperture at position “4” for general applications. Loose screws and

rotate left/right toward $C \sim 2.8$, the lighter working environment, the smaller aperture.

(C) Focal Length Adjustment: The focal length is from 12-36, each adjustment requires to adjust (A) Focus.

If the image is not clear after adjusted (A) and (C), means the focus distance is not correct. Please use Zoom in/out button on remote control to find clear image.

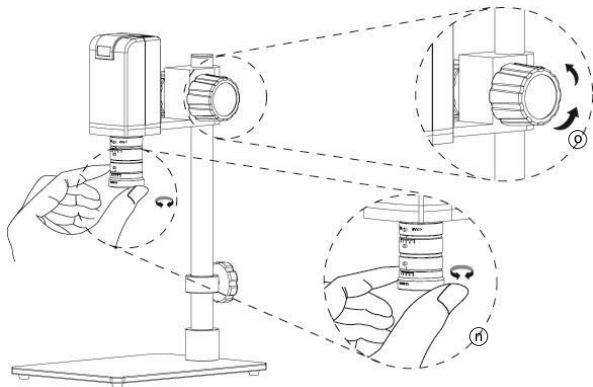

1.6.1 Magnification chart

This chart measured base on UM08-CSZ1236 on 24" screen.
This is only a reference data, might not be accurate enough.

CSZ1236 Zoom lens working distance: 300mm~20mm, (24" monitor) Ref data										
WD(mm)	300mm					200mm				
Aperture	4					4				
Focal length	12	15	20	26	36	12	15	20	26	36
FOV(mm)	141.5	115	89	70.8	53.5	98	80	63	50.5	39
Mag(X)	3.4	4.1	5.3	6.7	8.9	4.8	5.9	7.5	9.4	12.2

WD(mm)	100mm					20mm				
Aperture	4					4				
Focal length	12	15	20	26	36	12	15	20	26	36
FOV(mm)	56	47	37.5	31	24	12	15	20	27	10.8
Mag(X)	8.5	10.2	12.8	15.4	20	20	18	16	13.8	43

1.7 Microscope accessory

1.7.1 White balance card

The white side is used to calibrate the white balance. If the object is tiny, place it onto the white balance card and move the card instead of the object.

2. Printed Notice

Please read the following information before operating.

2.1 Maintenance

Please abide by the following rules while storing or using this product:

- 2.1.1 Keep dry: do not place the product in a humid environment. Dry surroundings help extend the life of the product.
- 2.1.2 Avoid temperature shock: temperature shock (for example, taking the product into a warm room from a cold environment) will cause internal condensation inside the machine. Please put the device inside the protection bag or handbag to prevent temperature shock, and avoid using the device in an environment with extreme temperatures.
- 2.1.3 Avoid dropping: the device may malfunction if it encounters strong collision, vibration, or distortion.
- 2.1.4 Turn the microscope off before cutting off the power supply : do not forced cut off the power supply.
- 2.1.5 Do not face the lens against strong light or sunshine for extended periods of time: Strong light rays may degrade sensitive elements and generate white stains on images.
- 2.1.6 Handle the device carefully: do not disassemble cables forcefully and avoid contact with the lens since they are subjected to damage.
- 2.1.7 Make sure to switch the power supply off and unplug the power cable if the device is not in operation for an extended period of time. Store the device in a dry environment with excellent ventilation. Do not expose the machine in an environment lower than -5°C or higher than 50°C.
- 2.1.8 While carrying, put the device inside the box to prevent from being damaged.

2.2 Product Specification

CMOS Sensor	2 million pixels CMOS sensor
Lens	CSZ1236 Zoom Lens
Magnification	Optical Zoom from 12-36.
Auxiliary source	Gooseneck Light.
DC port	Adaptor DC Input
HDMI port	Output 1080P(1920*1080 Pixel) image
Focus control	IR remote control
Power supplier	Adaptor (Output : DC 5.0V/2.0A Input : AC 100-240V 50/60Hz)
A/C Power Consumption	0.225A(Max)
Size	115(L)×66(W)×68(T) mm
Weight	Host weight around 710 grams
Operation environment	Temperature -5°C ~ 50°C; Humidity-lower than 85% (No Condensation)
For any changes, please visit http://www.vitiny.com	

Safety Instructions

- As an electronic product, please do not use the device in any place in which electronic products are prohibited.
- Keep the device away from water sources to avoid electric shock as it is not waterproof.
- Keep the device away from chemicals or substances with explosive or fire hazards. Switch the device off near gas stations.
- In the case that there are foreign substances or water inside the device, or the device is dropped or damaged, please switch off and remove the power supply to avoid fire and electric shock.
- Do not look steadily into Light sources after switching on the host as it is harmful to your eyes.
- Please use only the product accessories provided in the box for connections. Do not use any outside products without approval of original factory.
- Please remove the power supply from the microscope when not in use.
- Do not disassemble the machine for inspection. For any problems occurring in the machine itself, please power off the device and contact us through e-mail: mltc@vitiny.com

Contents of Warranty: The warranty is provided free of charge for faults caused by manufacturing within one year from the purchase date.

Non-warranty:

1. Product appearance parts, such as the outer casing, knobs and LED cover, etc (charged spare parts are limited to one year after completing the product manufacturing).
2. Consumption goods of the host itself, such as LED lights and lens.
3. Product accessories and fittings, such as the power supplier, HDMI cable, white balance card, remote controller...etc.

Services caused by any of the following situations in the period of the warranty shall not be provided free of charge:

1. Improper use or disassembly, repair or refitting.
2. Any damages to the device caused by external or environmental factors.
3. Discrepancy of product serial number, unfilled or unidentified warranty. Any inspection or repair service after the period of warranty will be charged as follows:
 - (1) Service fees (including transportation fees) of product inspection.
 - (2) Repair fees.
 - (3) Fees of replaced parts

ViTiny Service Center Tel: 07-657-9551 Fax: 07-657-9561

Address: 10 F., No.1, Section 1, Syuecheng Road, Dashu District, Kaohsiung City 840, Taiwan (R.O.C.)

Website: <http://www.vitiny.com>

ViTiny UM08-CSZ1236 Warranty

Product	
Model no	
S/L nos.	
Purchase date	DD/MM/YYYY
Purchaser	
Tel no:	
Address	
Email	
Distributor Seal for Confirmation	
(Stamp is necessary for validation of the Warranty)	
※Distributor's seal shall include name of the shop, telephone and address※	

Please ask the distributor to fill in the name of the shop, address, purchase date, and other contents to protect your rights and validate your one-year warranty since upon the purchase date.



[HTTP://WWW.VITINY.COM](http://www.vitiny.com)

© MicroLinks Technology Corp. All rights reserved.