

Optomistic Products
UNIVERSAL LIGHTPROBE™
EUROPEAN PARTNER
SHORT-FORM CATALOGUE



2017

DELIVERING THE BEST IN LED TEST
TO THE EUROPEAN MARKET
FAST!

TABLE OF CONTENTS

Overview of Two-Part Solution:	
Sensors and Fiber-Optic Probes.....	1
Sensors -	
Penta Sensor:	
Sensor for intensity and color test with analog output and built-in “binning” for five main LED colors and white.....	2
Spectra Sensor:	
Sensor for intensity and color test with analog output proportional to wavelength for any color in the visual spectrum, plus white.....	3
Spectra USB Sensor:	
Sensor for intensity and color test with a linear serial-digital output in tenths of nanometers for any color in the visual spectrum, plus white.....	4
Sensor Characteristics	
Penta, Spectra and Spectra USB Sensor Specifications.....	5
Fiber-Optic Probes -	
Small-Aperture Fiber-Optic Probes	
Single Flexible Cable Models.....	7
“Trident” & “Skinny Trident” Models.....	8
Wide-Aperture Fiber-Optic Probes:	
Flexible Cable Models.....	9
Side-Looking Fiber-Optic Probes.....	10
Installation Accessories:	
Clamps and connector cables.....	11
Sensor Six-Pack.....	12
Partner / Contact Information.....	13

Introducing Optimistic Products' Most Popular LED Test Solutions Now Stocked in Europe

Enjoy faster service for Optimistic Products most popular Universal LightProbes.
Contact you local distributor to take advantage of this offer.

UNIVERSAL LIGHTPROBE™ A TWO-PART SOLUTION FOR LED TESTING

The combination of various pre-programmed Sensors with a wide choice of **Fiber-Optic Probes**, produces a **Universal LightProbe™** that suits any LED test application. Start by choosing a pre-programmed Sensor for the type of test and output you require (Part 1), then, combine it with an interchangeable Fiber-optic Probe (Part 2) to further customize the test for mechanical requirements and constraints.

PART 1: SENSORS

Universal LightProbe Sensors are pre-programmed for various types of tests, and are available with a choice of outputs.



SENSORS:

Penta Sensor - Best selling sensor.
Features color-binning and intensity test.

Spectra Sensor - Features user-defined color-boundaries and intensity test.

Spectra USB Sensors - Test intensity and any color in the visual spectrum with a serial-digital output.
Popular for Functional Test.

PART 2: FIBER-OPTIC PROBES

Universal LightProbe Fiber-Optic Probes are combined with the Universal LightProbe Sensor.

FIBER-OPTIC PROBES:

Trident Fiber-Optic Probes - Enables the test of 3 LEDs with a single sensor for significant cost savings.

Super-Flex Wide-Aperture Fiber-optic Probes - with a bend radius of 6.35mm and a wide aperture - great for testing dim or mis-aligned LEDs.

Flexible Small-Aperture Fiber-Optic Probes - for testing closely spaced LEDs.

UNIVERSAL LIGHTPROBE™

PART 1 - SENSORS

UNIVERSAL LIGHTPROBE™ PENTA SENSORS:

Optomistic Products' best-selling Sensor, the Universal LightProbe Penta Sensor, provides analog voltage outputs for both color and intensity, and features built-in color binning, eliminating the need to convert LED wavelength to visual color in the ATE software, saving valuable processing time.



Part Number: ULP PCI/V

CHARACTERISTICS

- Typical response time: <340mS for color and intensity simultaneously
- Output Loads: 'Int.' & 'Color' - 2Kohms min., 100pF, max.
- Further details on Page 5

COLOR RESPONSE:

- Test for the five main LED colors, plus white
- Unambiguous and stable analog voltage output
- Color output is independent of LED intensity

Blue:	1.0 volts
Green:	1.5 volts
Yellow/Amber:	2.0 volts
Orange:	2.5 volts
Red:	3.0 volts
White:	3.5 volts

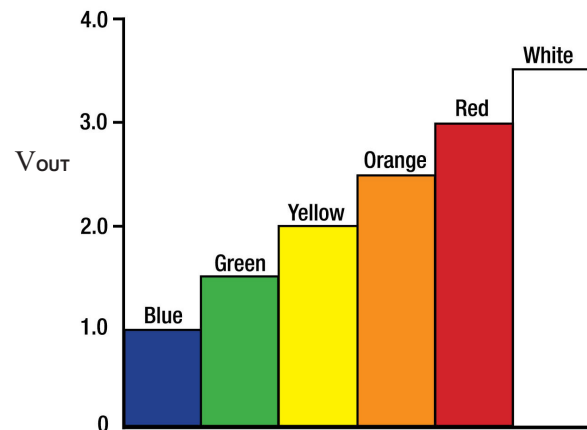

INTENSITY RESPONSE:

- Analog output ranging from 0 to 4 volts
- Corresponds to LED's luminous intensity in millicandelas
- C.I.E. photopic-curve-corrected
- Tests LEDs from 1 mcd to 20,000 mcd, and up to 315,000 mcd with the Penta Very-Low Sensitivity Sensor
- Read-out < 50mV indicates under-ranging - the LED is too dim; Penta High-Sensitivity Sensors are available
- Read-out > 4 volts indicates over-ranging - the LED is too bright; Penta Low-Sensitivity Sensors are available
- Intensity response depends on size of LED, the aperture of the fiber-optic probe and the distance between the probe tip and the LED emitter; for more information on Sensor Sensitivity Responses please see AN 35
- Available in Low and Very-Low-Sensitivity models for extremely bright LEDs

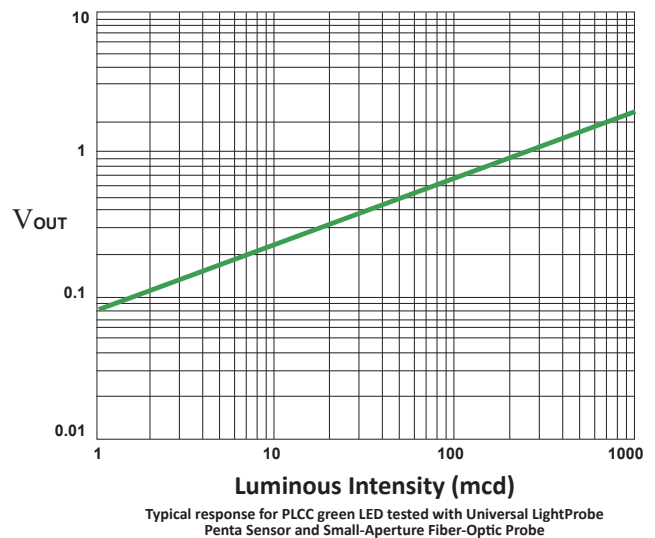

UNIVERSAL LIGHTPROBE™

PART 1 - SENSORS

UNIVERSAL LIGHTPROBE™ SPECTRA SENSORS:

Universal LightProbe Spectra Sensors test a wide range of LED intensity, and any color in the visual spectrum, plus white. Universal LightProbe Spectra Sensors are well-suited for the test of “boundary” color LEDs, as they allow the user to set their own PASS/FAIL limits for color.



Part Number: ULP WBI/V

CHARACTERISTICS

- Typical response time: <450mS for color and intensity simultaneously
- Output Loads: ‘Int.’& ‘Color’- 2Kohms min.,100pF, max.
- Further details on Page 5

COLOR RESPONSE

- Test any LED color wavelength from 400 to 700nm, plus white
- Unambiguous and stable analog voltage output proportional to LED wavelength
- LED Wavelength = $[100(V_{out} + 4)nm]$
- For white, the voltage output is 3.5volts
- Enables user to set their own PASS/FAIL limits
- Color output is independent of LED intensity
- Eliminates need to convert LED wavelength as a pulse rate
- Improves the overall response time to test an LED

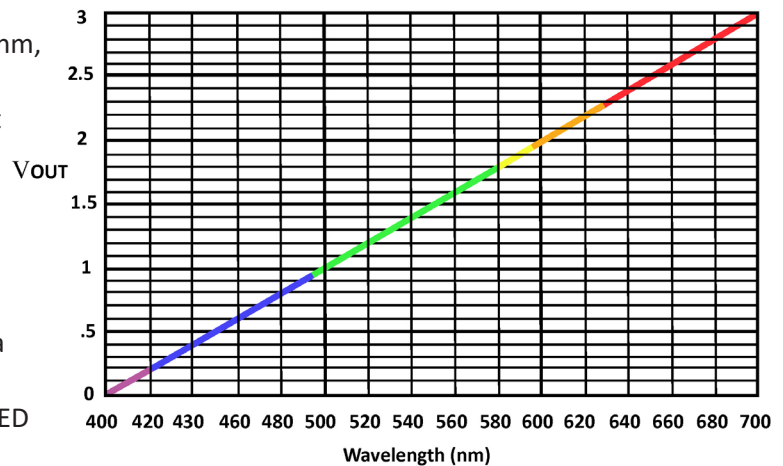

INTENSITY RESPONSE :

- Analog output ranging from 0 to 4 volts
- Corresponds to LED’s luminous intensity in millicandelas
- C.I.E. photopic-curve-corrected
- Tests LEDs from 1 mcd to 20,000 mcd, and up to 315,000 mcd with the Spectra Very-Low Sensitivity Sensor
- Read-out < 50mV indicates under-ranging - LED is too dim
- Read-out > 4 volts indicates over-ranging - the LED is too bright
- Intensity response depends on size of LED, the aperture of the fiber-optic probe and the distance between the probe tip and the LED emitter; for more information on Sensor Sensitivity Responses please see Application Note 35
- Available in Low and Very-Low Sensitivity models for extremely bright LEDs up to 315,000 mcd.

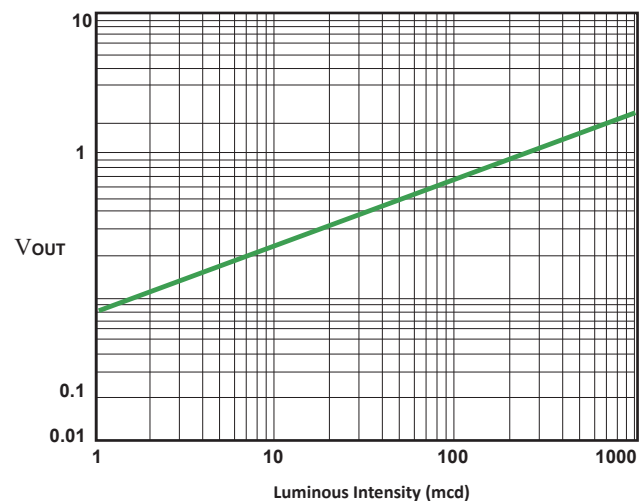

Typical response for PLCC green LED tested with Universal LightProbe Spectra Sensor and Small-Aperture Fiber-Optic Probe

UNIVERSAL LIGHTPROBE™

PART 1 - SENSORS

UNIVERSAL LIGHTPROBE™ SPECTRA USB SENSORS:

Universal LightProbe Spectra USB Sensors test a wide range of LED intensities and any color in the visual spectrum, plus white, providing a linear response with a serial digital output via a PC.



Part Number: ULP SPECTRA USB

CHARACTERISTICS

- A standard mini-type B five-pin USB connector is integrated into the Spectra USB Sensor, and a standard USB Cable is provided
- Typical response time: < 250mS for color and intensity as a serial bit-stream (19200 baud rate)

COLOR AND WHITE RESPONSE

- Test any color wavelength, from 400-700nm & white
- Provides serial-digital output of LED color
- "w" = color wavelength in tenths of nanometers
- Or, for white, "w" = a value that corresponds to CCT (see Application Note 39)
- Display/print-out the linear response with Tera Term software (included with purchase) See AN46 for details on LabView VISA
- Color output is independent of LED intensity
- Unique streaming technology enables LED color wavelength (and intensity) to be rapidly and simultaneously accessed by a PC and displayed/printed-out
- Reduces test time and provides continuous automatic data logging for statistical process control (SPC).
- Multiport display is available

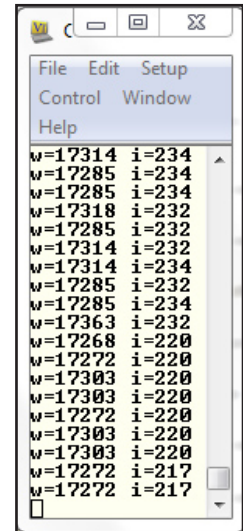
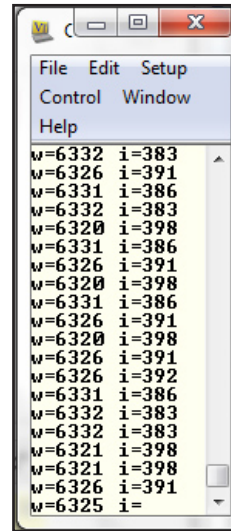

INTENSITY RESPONSE

- Provides serial digital output for LED intensity
- "i" = intensity, from 0 to 65,0000
- Output corresponds to LED luminous intensity in millicandelas, as seen in most LED manufacturers' specifications
- C.I.E. photopic-curve-corrected
- Tests LEDs from 0.03mcd to 18,300mcd; up to 293,000mcd with the Spectra USB Very-Low Sensitivity Sensor
- Read-out of 4 indicates under-ranging - LED is too dim
- Read-out > over 65,000 indicates over-ranging - LED too bright; Spectra USB Low-Sensitivity Sensors available
- Intensity response depends on size of LED, the aperture of the fiber-optic probe and the distance between the probe tip and the LED emitter; for more information on Sensor Sensitivity Responses in millicandelas, please see AN 35
- Available in Low and Very-Low Sensitivity models for the test of extremely bright LEDs

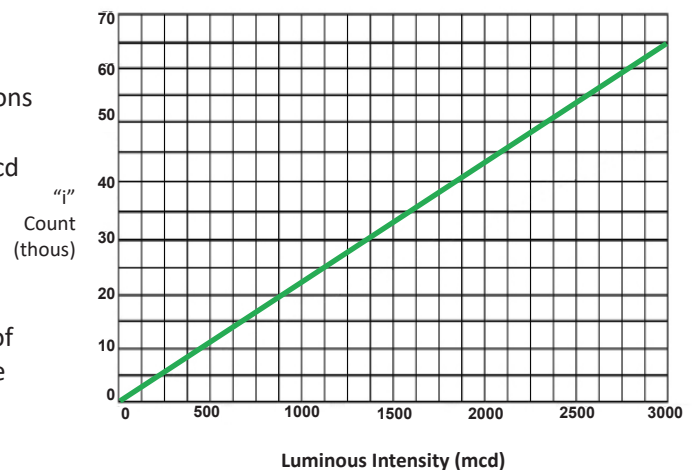

Typical response for PLCC green LED tested with Universal LightProbe Spectra USB Sensor and Small-Aperture Fiber-Optic Probe

UNIVERSAL LIGHTPROBE™

PART 1 - SENSORS

PIN CONNECTIONS, DIMENSIONS AND OUTPUT SIGNAL CHARACTERISTICS:

All Universal LightProbe Sensors share the same form, and are then pre-programmed to suit specific LED test requirements.

Operating temperature range: 0°C to 70°C

Power consumption: Operates from +5, 12, 24 or 28 volts D.C., at 5mA max.

Voltage protection: Withstands up to +40 volts, & reverse polarity to -18 volts

Output Pins: 3 or 4 gold-plated (depending on sensor type) standard wire-wrap pins (0.025 in. sq.) **OR** USB

PENTA (PCI/V) and SPECTRA (WBI/V) SENSORS: Four standard wire-wrap pins

G - Ground - common for analog output and power input

I - Intensity of LED under test (relative)

C - Color of LED under test

P - DC Power Input, +5, 12, 24, or 28 volts

Typical response times: Penta <340mS; Spectra <450mS color & intensity outputs simultaneously

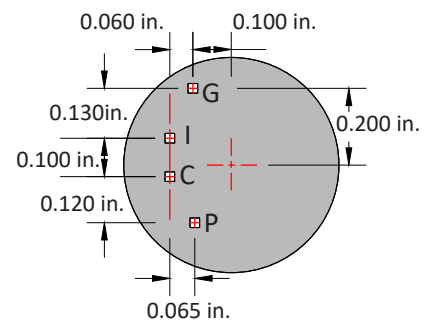
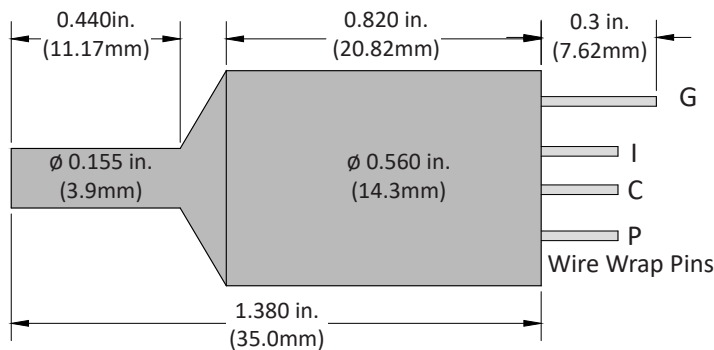

SPECTRA USB SENSOR:

Connection is a USB port: sensor includes compatible standard mini-B type USB cable

Typical response time: <250mS color & intensity output as a serial bit-stream (19200 baud rate)

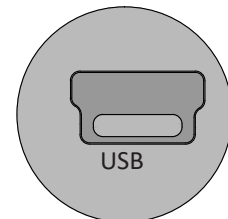
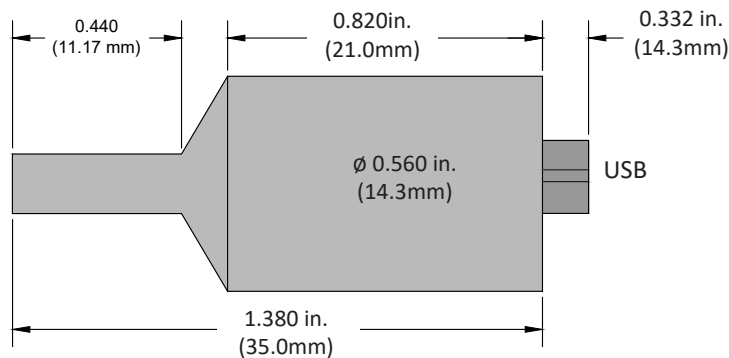

UNIVERSAL LIGHTPROBE™

PART 2 - FIBER-OPTIC PROBES

UNIVERSAL LIGHTPROBE™ FIBER-OPTIC PROBE SELECTION GUIDE

After choosing a pre-programmed **Sensor** for the type of test and output you require, then choose a **Fiber-optic Probe** to further customize the test for mechanical requirements and constraints.

SMALL-APERTURE (SA) FLEXIBLE FIBER-OPTIC PROBES:

SINGLE:



Characteristics:

- Flexible cable: 1 x 9.84 in./250mm long.
- Probe tip dia.: 0.050 in. /1.27mm
- LED spacing: Not less than 0.050 in. / 1.27mm
- Minimum bend radius: 50.8mm
- Probe tip type: Stainless-steel
- Air-gap: 1mm min. recommended
- See probe tip lengths below

PART NUMBERS:

There are 2 tip styles in the **Small-Aperture Flexible Single** model available to account for variations in working distance, LED orientation and accessibility, **Short (SL)** and **Long (LL)**. For testing side-facing LEDs, use **Side-Looking (P)** probes - see **page 9**.

250-12-SL-SA
28.57mm tip



250-12-LL-SA
44.45mm tip



UNIVERSAL LIGHTPROBE™

PART 2 - FIBER-OPTIC PROBES

SMALL-APERTURE (SA) FLEXIBLE FIBER-OPTIC PROBES - continued:

TRIDENT AND SKINNY TRIDENT: For the testing of three LEDs sequentially with one sensor.

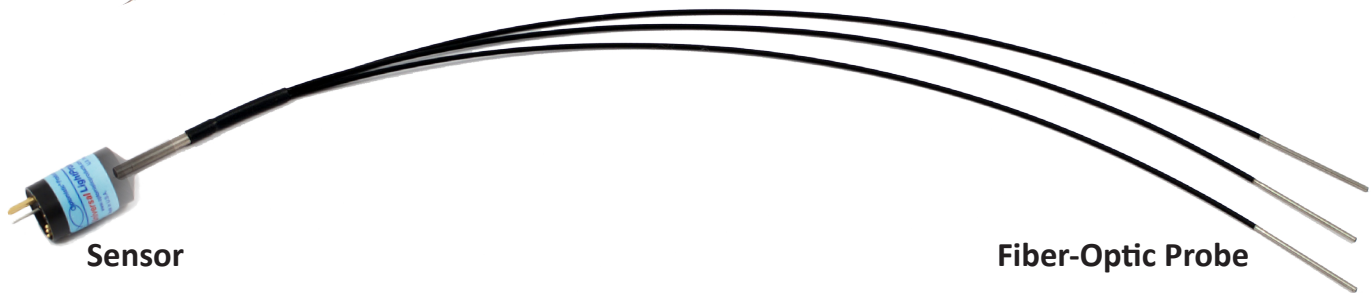

Characteristics:

- Flexible cable: 3 x 9.84 in. / 250mm long
- Air-gap: 1mm min. recommended
- LED spacing: Not less than 0.050 in. / 1.27mm
- Minimum bend radius: 50.8mm
- Probe tip dia.: 0.050 in. / 1.27mm
- LEDs must be turned on and tested one at a time per sensor
- Probe tip type: Stainless-steel

PART NUMBERS:

Trident - (250-12x12) (individual probes are replaceable)

Skinny Trident - (250T/13) (individual probes are NOT replaceable)

Short (SL) and Long (LL)

For testing side-facing LEDs use **Side-Looking (P)** probes - see page 9.

250T-12x12-SL-SA

250T/13-12-SL-SA

28.57mm tips

250T-12x12-LL-SA

250T/13-12-LL-SA

4.45mm tips



UNIVERSAL LIGHTPROBE™ PART 2 - FIBER-OPTIC PROBES

WIDE-APERTURE (WA) SUPER-FLEXIBLE FIBER-OPTIC PROBES : Allows more light input than small-aperture probes, compensating for dim LEDs and potential misalignment errors in ATE test fixtures.



Characteristics:

- Super flexible cable: 9.84in. / 250mm long
- Probe tip diameter: 0.109in./2.77mm stainless-steel tip
- Air-gap: 1mm recommended- up to 3mm to increase field of view when testing misaligned LEDs
- Probe tip type: non-contacting stainless steel
- LED spacing: not less than 0.109in./2.77mm
- Minimum bend radius: 6.35mm

PART NUMBERS:

Wide-Aperture Super-Flex model is available in **Short (SL)** and **Long (LL)** models.

For testing side-facing LEDs use **Side-Looking (P)** probes - see page 8.

250SF-27-SL-WA
8.25mm tip



250SF-27-LL-WA
35mm tip



UNIVERSAL LIGHTPROBE™

PART 2 - FIBER-OPTIC PROBES

SIDE-LOOKING FIBER-OPTIC PROBES:

Optomistic Products has designed new Fiber-optic Probes to address the challenge of testing side-facing LEDs. The new design tolerates lateral misalignment, making it easier to test side-facing LEDs with very low height profiles.

Available in both wide-aperture and small-aperture sizes as well as the popular and cost-effective “Trident” assembly, which can test 3 side-facing LEDs with a single sensor.

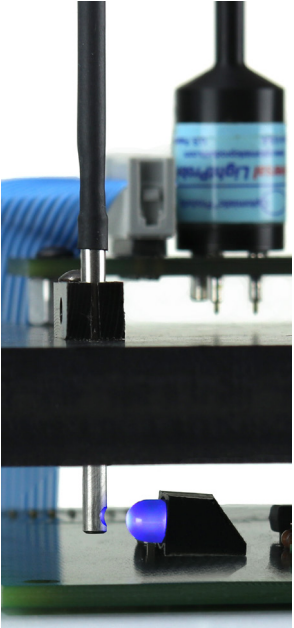
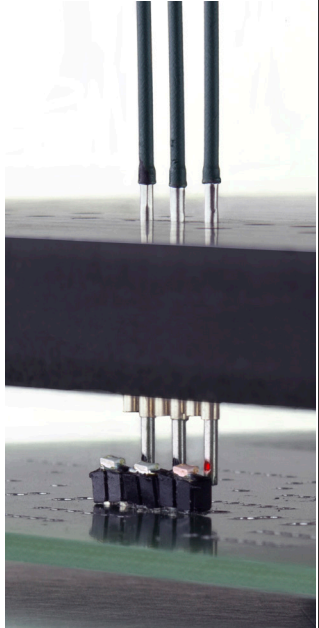
<p style="text-align: center;">WIDE-APERTURE SIDE-LOOKING PROBE</p> <p>Characteristics:</p> <ul style="list-style-type: none"> • Flexible cable: 1 x 9.84 in. / 250mm long / 1 in. bend radius • Probe tip dia.: 2.77mm • Air-gap: 1mm min. recommended 	<p style="text-align: center;">SMALL-APERTURE SIDE-LOOKING PROBE</p> <p>Characteristics:</p> <ul style="list-style-type: none"> • Available in single or Trident models • Flexible cable: 1 x 9.84 in. / 250mm long / 1 in. bend radius • Probe tip dia.: 1.27mm • Air-gap: 1mm min. recommended 
---	---

PART NUMBERS:

Wide-Aperture
250-27P-LL-WA
 1.375 in. stainless-steel tip



Small-Aperture
250-12P-SL-SA
 1.125 in. stainless-steel tip



Trident
250T-12x12P-SL-SA
 1.125 in. stainless-steel tips



UNIVERSAL LIGHTPROBE™

INSTALLATION ACCESSORIES

Universal LightProbe™ Sensors and Fiber-Optic Probes are easy and fast to install. The **Sensor Six-Pack** - see **Page 9** - can accommodate Six Universal LightProbe Sensors in a single space-saving unit. Use one-hole fixing clamps for the sensors and flexible cable fiber-optic probes. Stainless-steel encased Fiber-Optic Probes support both the sensor and the Fiber-Optic Probe without sensor clamps. The **Universal LightProbe™ Connector Cable** is also available for quick and easy sensor wiring to ATE interface.

MOUNTING CLAMPS:

Sensor Clamp: Part Number ULP-CP

Use a single clamp for the sensor with a single #10-ANSI screw for one-hole fixing



Probe Clamp: Part Number LCP-XXX

("XX = Fiber-Optic Probe model number - 12P or 27P)

Individual clamps secured to the probe plate, allows the height of the probe tips above the LEDs to be adjusted



Socket Clamp: Part Number LCP-S12

Secures the stainless-steel tips in the probe plate. For small-aperture fiber-optic-probes, including the popular "Trident" fiber-optic probe. See AN 22 for more information.

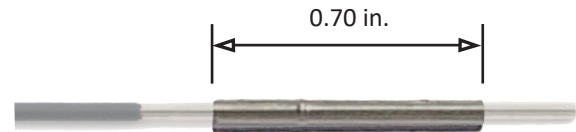

Universal LightProbe™ Connector Cable: Part Number ULP-CC

- Fool-proof Sensor Wiring

Color-coded and labeled wires, corresponding to sensor pin labelling, with separate sheathing of individual sensor wires for easy identification at the ATE interface

- Time-Saving

Provides a quick-change of sensors, saving time over wire-wrap connections

- Reduces Overall Fixture Assembly Cost

Eliminates costly wiring errors and de-bug time and provides automatic dressing of specific sensor wires.

- Protects Sensor from Heat Damage

Eliminates the possibility of sensor damage caused by excessive heat.
(Soldering connections NOT recommended)

- Long, Durable, Flexible and Tested

Long-length (48 inches/1220mm) allows for trimming to suit most fixtures and 26 AWG stranded conductors for flexibility and durability. End-to-end continuity tested and pull tested



UNIVERSAL LIGHTPROBE™ SENSOR SIX-PACK:

The Universal LightProbe Sensor Six-Pack provides a compact and efficient way to install six Universal LightProbe Sensors in a single space-saving unit. The convenient installation provides two standard circuit-board header connectors, enabling the use of standard ribbon cable connectors for the Universal LightProbe Sensors' output. A single power and a single ground wire is all that is needed to connect as many as six Sensors.

The Sensor Six-Pack will accommodate any combination of the pre-programmed Universal LightProbe Sensor models, which can then be paired with a wide variety of Fiber-optic Probes to customize for a specific test. For example, the popular Penta Sensor can be combined with "Trident" Fiber-optic Probes to test 18 LEDs.



Easy Installation: Two tapped (4-40) mounting holes are used for installation with 1/4 in. stand-offs. Both 10-pin and 14-pin standard circuit-board header connectors accommodate either analog or digital Sensor outputs.

See Application Note **AN47** for details on installation

Note: Ribbon cable / wire-wrap / stand-offs to be supplied by customer

UNIVERSAL LIGHTPROBE SENSOR SIX-PACK SHOWN WITH SENSORS AND COMBINATION OF VARIOUS FIBER-OPTIC PROBES

PART NUMBER: S6P (Sensors and Fiber-optic Probes sold separately)

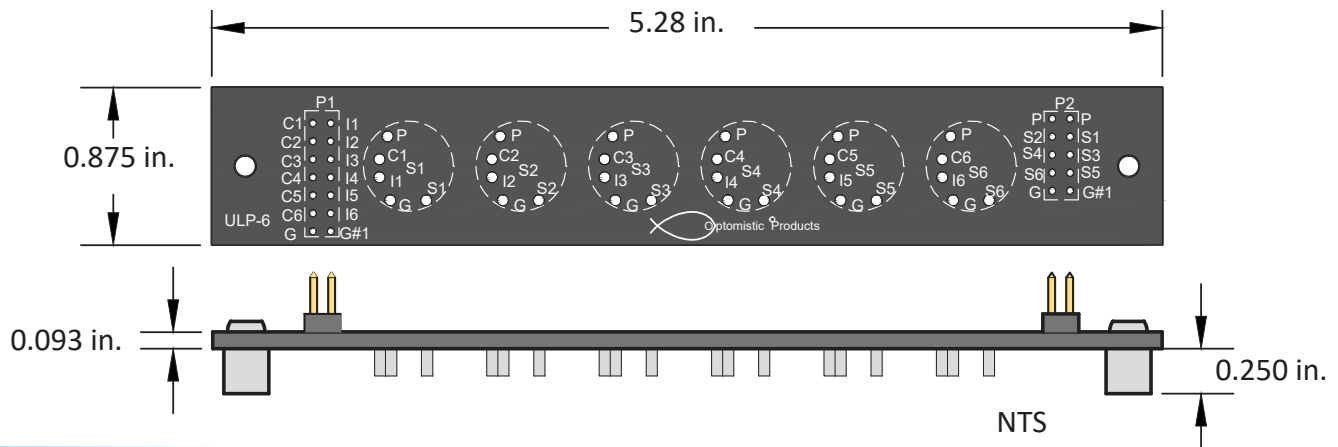

www.optomisticproducts.com

European Partner Short-Form Catalogue

PARTNER / CONTACT INFORMATION



Rest of Europe: Opto-Europe
opto-europe@optomisticproducts.com 

For the complete catalogue of Optomistic Products LED test solutions, please contact your Distributor,
or visit www.optomisticproducts.com

www.optomisticproducts.com

European Partner Short-Form Catalogue